

# Quantum Bruhat graphs and tilted Richardson varieties

Jiyang (Johnny) Gao (Harvard)

Joint work with: Shiliang Gao (UIUC) and Yibo Gao (PKU)

Cornell DCG Seminar, Apr 22 2024

# Big Picture

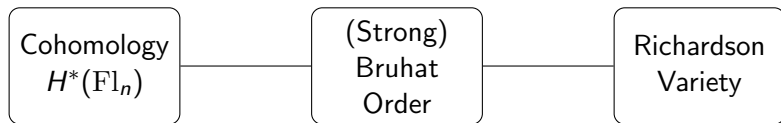

# Big Picture

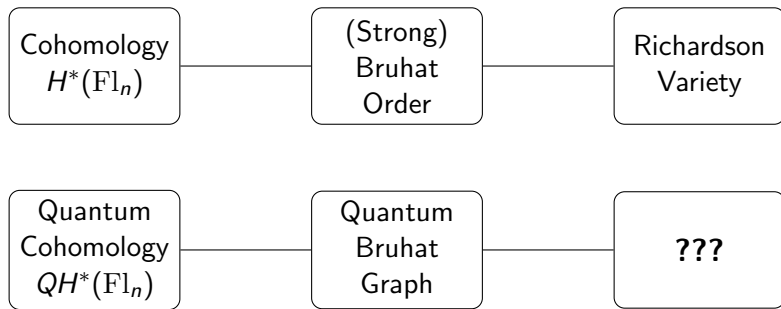

# Big Picture

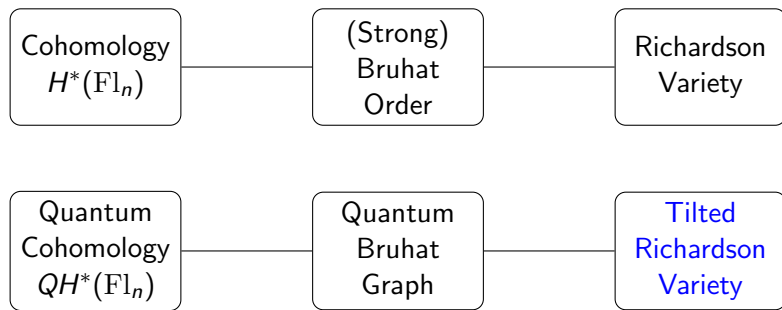

- Combinatorially explicitly defined
- Geometrically beautiful
- Related to Total Positivity, Kazhdan-Lusztig Polynomials...

# Outline

- Background: Quantum Cohomology
- Quantum Bruhat Graphs
- Tilted Richardson varieties
- Tilted Deodhar decomposition

# Quantum Cohomology of Flag Varieties

Let  $Fl_n = GL_n(\mathbb{C})/B$  be the **complete flag variety** over  $\mathbb{C}$ .

# Quantum Cohomology of Flag Varieties

Let  $\text{Fl}_n = \text{GL}_n(\mathbb{C})/B$  be the **complete flag variety** over  $\mathbb{C}$ .

The cohomology ring  $H^*(\text{Fl}_n)$  has an  $\mathbb{Z}$ -basis given by Schubert classes  $\{\sigma_w : w \in S_n\}$ , where  $\sigma_w$  is the cohomology class of Schubert variety  $X_w$ .

# Quantum Cohomology of Flag Varieties

Let  $Fl_n = GL_n(\mathbb{C})/B$  be the **complete flag variety** over  $\mathbb{C}$ .

The cohomology ring  $H^*(Fl_n)$  has an  $\mathbb{Z}$ -basis given by Schubert classes  $\{\sigma_w : w \in S_n\}$ , where  $\sigma_w$  is the cohomology class of Schubert variety  $X_w$ .

The **quantum cohomology ring**  $QH^*(Fl_n) \cong H^*(Fl_n) \otimes_{\mathbb{Z}} \mathbb{Z}[q_1, \dots, q_{n-1}]$  has an  $\mathbb{Z}[q]$ -basis given by Schubert classes  $\{\sigma_w : w \in S_n\}$ .

[Givental-Kim '95, Ciocan-Fontani '95, Fomin-Gelfand-Postnikov '97]

# Quantum Cohomology of Flag Varieties

Let  $Fl_n = GL_n(\mathbb{C})/B$  be the **complete flag variety** over  $\mathbb{C}$ .

The cohomology ring  $H^*(Fl_n)$  has an  $\mathbb{Z}$ -basis given by Schubert classes  $\{\sigma_w : w \in S_n\}$ , where  $\sigma_w$  is the cohomology class of Schubert variety  $X_w$ .

The **quantum cohomology ring**  $QH^*(Fl_n) \cong H^*(Fl_n) \otimes_{\mathbb{Z}} \mathbb{Z}[q_1, \dots, q_{n-1}]$  has an  $\mathbb{Z}[q]$ -basis given by Schubert classes  $\{\sigma_w : w \in S_n\}$ .

[Givental-Kim '95, Ciocan-Fontani '95, Fomin-Gelfand-Postnikov '97]

When  $q_1 = \dots = q_{n-1} = 0$ , we recover  $H^*(Fl_n)$ .

# Quantum Cohomology of Flag Varieties

The **quantum cohomology ring**  $QH^*(\mathbb{F}l_n) \cong H^*(\mathbb{F}l_n) \otimes_{\mathbb{Z}} \mathbb{Z}[q_1, \dots, q_{n-1}]$  is generated by Schubert classes  $\{\sigma_w : w \in S_n\}$ .

# Quantum Cohomology of Flag Varieties

The **quantum cohomology ring**  $QH^*(\mathbb{F}l_n) \cong H^*(\mathbb{F}l_n) \otimes_{\mathbb{Z}} \mathbb{Z}[q_1, \dots, q_{n-1}]$  is generated by Schubert classes  $\{\sigma_w : w \in S_n\}$ .

We are interested in understanding products:

$$\sigma_u \star \sigma_v = \sum_{w,d} c_{u,v}^{w,d} q^d \sigma_w$$

where  $d = (d_1, \dots, d_{n-1}) \in \mathbb{Z}_{\geq 0}^{n-1}$  and  $q^d := q_1^{d_1} \cdots q_{n-1}^{d_{n-1}}$ .

# Quantum Cohomology of Flag Varieties

The **quantum cohomology ring**  $QH^*(\mathbb{F}l_n) \cong H^*(\mathbb{F}l_n) \otimes_{\mathbb{Z}} \mathbb{Z}[q_1, \dots, q_{n-1}]$  is generated by Schubert classes  $\{\sigma_w : w \in S_n\}$ .

We are interested in understanding products:

$$\sigma_u \star \sigma_v = \sum_{w,d} c_{u,v}^{w,d} q^d \sigma_w$$

where  $d = (d_1, \dots, d_{n-1}) \in \mathbb{Z}_{\geq 0}^{n-1}$  and  $q^d := q_1^{d_1} \cdots q_{n-1}^{d_{n-1}}$ .

- 1 What weights  $q^d$  appear in  $\sigma_u \star \sigma_v$ ? What is the minimal  $q^{d_{\min}}$ ?
- 2 If  $q^d$  appears, what is  $[q^d]\sigma_u \star \sigma_v \in H^*(\mathbb{F}l_n)$ ?

# Quantum Cohomology of Flag Varieties

The **quantum cohomology ring**  $QH^*(\mathbb{F}l_n) \cong H^*(\mathbb{F}l_n) \otimes_{\mathbb{Z}} \mathbb{Z}[q_1, \dots, q_{n-1}]$  is generated by Schubert classes  $\{\sigma_w : w \in S_n\}$ .

We are interested in understanding products:

$$\sigma_u \star \sigma_v = \sum_{w,d} c_{u,v}^{w,d} q^d \sigma_w$$

where  $d = (d_1, \dots, d_{n-1}) \in \mathbb{Z}_{\geq 0}^{n-1}$  and  $q^d := q_1^{d_1} \cdots q_{n-1}^{d_{n-1}}$ .

- 1 What weights  $q^d$  appear in  $\sigma_u \star \sigma_v$ ? What is the minimal  $q^{d_{\min}}$ ?  
**Known** [Fulton-Woodward '04, Postnikov '05, Buch-Chung-Li-Mihalcea '20]
- 2 If  $q^d$  appears, what is  $[q^d]\sigma_u \star \sigma_v \in H^*(\mathbb{F}l_n)$ ?  
**Geometric but not combinatorial!** [Buch-Chaput-Mihalcea-Perrin '13]

# Quantum Bruhat Graph

Postnikov ('05) related all quantum degrees  $q^d$  appearing in  $\sigma_u \star \sigma_{w_0 v}$  to weights of paths on the quantum Bruhat graph.

# Quantum Bruhat Graph

Postnikov ('05) related all quantum degrees  $q^d$  appearing in  $\sigma_u \star \sigma_{w_0 v}$  to weights of paths on the quantum Bruhat graph.

Definition (Brenti-Fomin-Postnikov '99)

The **quantum Bruhat graph**  $\Gamma_n$  is a weighted directed graph on  $S_n$  with the following two types of edges:

# Quantum Bruhat Graph

Postnikov ('05) related all quantum degrees  $q^d$  appearing in  $\sigma_u \star \sigma_{w_0 v}$  to weights of paths on the quantum Bruhat graph.

## Definition (Brenti-Fomin-Postnikov '99)

The **quantum Bruhat graph**  $\Gamma_n$  is a weighted directed graph on  $S_n$  with the following two types of edges:

- Strong Bruhat edges:  $w \rightarrow wt_{ij}$  of weight 1  
if  $w_i < w_j$  and  $\#$ 's in between are not in between  
(e.g.  $43\underline{2}718\underline{6}5 \xrightarrow{1} 43\underline{6}718\underline{2}5$ )

# Quantum Bruhat Graph

Postnikov ('05) related all quantum degrees  $q^d$  appearing in  $\sigma_u \star \sigma_{w_0 v}$  to weights of paths on the quantum Bruhat graph.

## Definition (Brenti-Fomin-Postnikov '99)

The **quantum Bruhat graph**  $\Gamma_n$  is a weighted directed graph on  $S_n$  with the following two types of edges:

- Strong Bruhat edges:  $w \rightarrow wt_{ij}$  of weight 1  
if  $w_i < w_j$  and  $\#$ 's in between are not in between  
(e.g.  $43\underline{2}7\underline{1}8\underline{6}5 \xrightarrow{1} 43\underline{6}7\underline{1}8\underline{2}5$ )
- Quantum edges:  $w \rightarrow wt_{ij}$  of weight  $q_{ij} := q_i \cdots q_{j-1}$   
if  $w_i > w_j$  and  $\#$ 's in between are all in between  
(e.g.  $18\underline{7}53\underline{2}46 \xrightarrow{q_3 q_4 q_5} 18\underline{2}53\underline{7}46$ )

# Quantum Bruhat Graph

## Example (Quantum Bruhat graph $\Gamma_3$ )

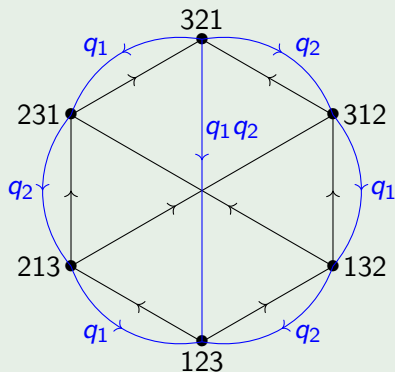

# Combinatorial Properties of $\Gamma_n$

## Theorem (Postnikov '05)

*For  $u, v \in S_n$ , all shortest paths  $u \rightarrow v$  in  $\Gamma_n$  have the same weight  $q^{d_{min}}$ . Such  $q^{d_{min}}$  is the unique minimal  $q^d$  that appears in  $\sigma_u \star \sigma_{w_0 v}$ .*

# Combinatorial Properties of $\Gamma_n$

## Theorem (Postnikov '05)

For  $u, v \in S_n$ , all shortest paths  $u \rightarrow v$  in  $\Gamma_n$  have the same weight  $q^{d_{\min}}$ . Such  $q^{d_{\min}}$  is the unique minimal  $q^d$  that appears in  $\sigma_u \star \sigma_{w_0 v}$ .

Example (All shortest paths from  $u = 231$  to  $v = 123$ )

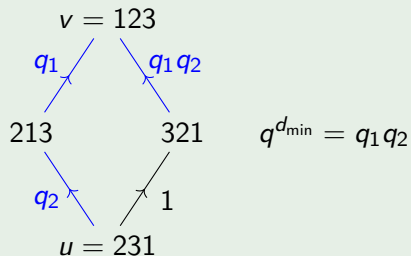

# Combinatorial Properties of $\Gamma_n$

## Theorem (Postnikov '05)

For  $u, v \in S_n$ , all shortest paths  $u \rightarrow v$  in  $\Gamma_n$  have the same weight  $q^{d_{\min}}$ . Such  $q^{d_{\min}}$  is the unique minimal  $q^d$  that appears in  $\sigma_u \star \sigma_{w_0 v}$ .

Example (All shortest paths from  $u = 231$  to  $v = 123$ )

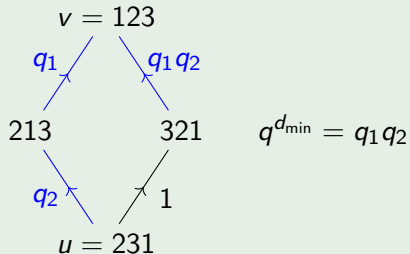

The collection of all shortest paths  $u \rightarrow v$  form a poset called the **tilted Bruhat interval**  $[u, v]_q$ .

It is a graded poset with minimum  $\hat{0} = u$  and maximum  $\hat{1} = v$ .

## Curve Neighbourhoods (alert: geometry!!)

Buch-Chaput-Mihalcea-Perrin ('13) related  $[q^d]\sigma_u \star \sigma_{w_0v} \in H^*(\mathbb{F}l_n)$  to the cohomology class of a certain subvariety in  $\mathbb{F}l_n$ .

# Curve Neighbourhoods (alert: geometry!!)

Buch-Chaput-Mihalcea-Perrin ('13) related  $[q^d]\sigma_u \star \sigma_{w_0v} \in H^*(\mathbb{F}l_n)$  to the cohomology class of a certain subvariety in  $\mathbb{F}l_n$ .

## Definition (Buch-Chaput-Mihalcea-Perrin '13)

For  $u, v \in S_n$ , and degree  $d = (d_1, \dots, d_{n-1})$  the **two-pointed curve neighborhood**  $\Gamma_d(X^u, X_v)$  is the union of all degree  $d$  rational curves that passes through both Schubert varieties  $X^u$  and  $X_v$  in  $\mathbb{F}l_n$ .

## Curve Neighbourhoods (alert: geometry!!)

Buch-Chaput-Mihalcea-Perrin ('13) related  $[q^d]\sigma_u \star \sigma_{w_0v} \in H^*(\mathbb{F}l_n)$  to the cohomology class of a certain subvariety in  $\mathbb{F}l_n$ .

### Definition (Buch-Chaput-Mihalcea-Perrin '13)

For  $u, v \in S_n$ , and degree  $d = (d_1, \dots, d_{n-1})$  the **two-pointed curve neighborhood**  $\Gamma_d(X^u, X_v)$  is the union of all degree  $d$  rational curves that passes through both Schubert varieties  $X^u$  and  $X_v$  in  $\mathbb{F}l_n$ .

Fact: When  $q^d$  appears in  $\sigma_u \star \sigma_{w_0v}$ , we have:

$$[\Gamma_d(X^u, X_v)] = \frac{1}{c} [q^d] \sigma_u \star \sigma_{w_0v} \in H^*(\mathbb{F}l_n),$$

for some  $c \in \mathbb{Z}_{>0}$ .

# Curve Neighbourhoods

- In the Grassmannian, the curve neighborhoods are positroid varieties [Knutson-Lam-Speyer '13];
- In cominuscule  $G/P$ , they are projected Richardson varieties [Buch-Chaput-Mihalcea-Perrin '18].

# Curve Neighbourhoods

- In the Grassmannian, the curve neighborhoods are positroid varieties [Knutson-Lam-Speyer '13];
- In cominuscle  $G/P$ , they are projected Richardson varieties [Buch-Chaput-Mihalcea-Perrin '18].

In the complete flag variety,

- If  $d = (0, \dots, 0)$ ,  $\Gamma_d(X^u, X_v) = \mathcal{R}_{u,v} (:= X^u \cap X_v)$  is the Richardson variety;
- If  $d = (0, \dots, 0, 1, 0, \dots)$ , then  $\Gamma_d(X^u, X_v)$  is a Richardson variety [L-M'13];
- If  $u = \text{id}$ , then  $\Gamma_d(X^u, X_v) = X_{v(d)}$  is a Schubert variety [B-M'15];
- $\Gamma_d(X^u, X_v)$  is empty unless  $d \geq d_{\min}$  coordinate-wise [F-W'04].

# Curve Neighbourhoods

- In the Grassmannian, the curve neighborhoods are positroid varieties [Knutson-Lam-Speyer '13];
- In cominuscle  $G/P$ , they are projected Richardson varieties [Buch-Chaput-Mihalcea-Perrin '18].

In the complete flag variety,

- If  $d = (0, \dots, 0)$ ,  $\Gamma_d(X^u, X_v) = \mathcal{R}_{u,v} (:= X^u \cap X_v)$  is the Richardson variety;
- If  $d = (0, \dots, 0, 1, 0, \dots)$ , then  $\Gamma_d(X^u, X_v)$  is a Richardson variety [L-M'13];
- If  $u = \text{id}$ , then  $\Gamma_d(X^u, X_v) = X_{v(d)}$  is a Schubert variety [B-M'15];
- $\Gamma_d(X^u, X_v)$  is empty unless  $d \geq d_{\min}$  coordinate-wise [F-W'04].

Motivating Q: Is there a combinatorial description for  $\Gamma_d(X^u, X_v)$ ?

When  $d = d_{\min} \Rightarrow$  **Tilted Richardson Varieties**

# Tilted Richardson Varieties

For  $u, v \in S_n$  and a sequence  $\mathbf{a} = (a_1, \dots, a_{n-1}) \in [n]^{n-1}$ , we define the **tilted Richardson variety/cell**  $\mathcal{T}_{u,v,\mathbf{a}}$  (and  $\mathcal{T}_{u,v,\mathbf{a}}^\circ$ ) in  $\mathbb{F}l_n$  as follows.

# Tilted Richardson Varieties

For  $u, v \in S_n$  and a sequence  $\mathbf{a} = (a_1, \dots, a_{n-1}) \in [n]^{n-1}$ , we define the **tilted Richardson variety/cell**  $\mathcal{T}_{u,v,\mathbf{a}}$  (and  $\mathcal{T}_{u,v,\mathbf{a}}^\circ$ ) in  $\mathbb{F}l_n$  as follows.

## Example

Consider  $u = 4321(\star)$ ,

$$M =$$

			★	1
		★		2
	★			3
★				4

# Tilted Richardson Varieties

For  $u, v \in S_n$  and a sequence  $\mathbf{a} = (a_1, \dots, a_{n-1}) \in [n]^{n-1}$ , we define the **tilted Richardson variety/cell**  $\mathcal{T}_{u,v,\mathbf{a}}$  (and  $\mathcal{T}_{u,v,\mathbf{a}}^\circ$ ) in  $\mathbb{F}l_n$  as follows.

## Example

Consider  $u = 4321(\star)$ ,  $v = 3142(\bullet)$ ,

$$M =$$

	$\bullet$		$\star$	1
		$\star$	$\bullet$	2
$\bullet$	$\star$			3
$\star$		$\bullet$		4

# Tilted Richardson Varieties

For  $u, v \in S_n$  and a sequence  $\mathbf{a} = (a_1, \dots, a_{n-1}) \in [n]^{n-1}$ , we define the **tilted Richardson variety/cell**  $\mathcal{T}_{u,v,\mathbf{a}}$  (and  $\mathcal{T}_{u,v,\mathbf{a}}^\circ$ ) in  $\mathbb{F}l_n$  as follows.

## Example

Consider  $u = 4321(\star)$ ,  $v = 3142(\bullet)$ , and  $\mathbf{a} = (4, 2, 2)(-)$ .

$$M =$$

	•		★	1
		★	•	2
•	★			3
★		•		4

# Tilted Richardson Varieties

For  $u, v \in S_n$  and a sequence  $\mathbf{a} = (a_1, \dots, a_{n-1}) \in [n]^{n-1}$ , we define the **tilted Richardson variety/cell**  $\mathcal{T}_{u,v,\mathbf{a}}$  (and  $\mathcal{T}_{u,v,\mathbf{a}}^\circ$ ) in  $\mathbb{F}l_n$  as follows.

## Example

Consider  $u = 4321(\star)$ ,  $v = 3142(\bullet)$ , and  $\mathbf{a} = (4, 2, 2)(-)$ .

Rank conditions in the left  $k$  columns for each  $k \in \{1, 2, 3\}$ . When  $k = 2$ :

Start from the row below red line and go down:

$$M = \begin{array}{cccc|c} \hline & \bullet & & \star & 1 \\ \hline & & \star & \bullet & 2 \\ \hline \bullet & \star & & & 3 \\ \hline \star & & \bullet & & 4 \\ \hline \end{array}$$

$k = 2$

# Tilted Richardson Varieties

For  $u, v \in S_n$  and a sequence  $\mathbf{a} = (a_1, \dots, a_{n-1}) \in [n]^{n-1}$ , we define the **tilted Richardson variety/cell**  $\mathcal{T}_{u,v,\mathbf{a}}$  (and  $\mathcal{T}_{u,v,\mathbf{a}}^\circ$ ) in  $\mathbb{F}l_n$  as follows.

## Example

Consider  $u = 4321(\star)$ ,  $v = 3142(\bullet)$ , and  $\mathbf{a} = (4, 2, 2)(-)$ .

Rank conditions in the left  $k$  columns for each  $k \in \{1, 2, 3\}$ . When  $k = 2$ :

Start from the row below red line and go down:

$$M = \begin{array}{|c|c|c|c|} \hline & \bullet & & \star & 1 \\ \hline \text{green} & \text{green} & \star & \bullet & 2 \\ \hline \bullet & \star & & & 3 \\ \hline \star & & \bullet & & 4 \\ \hline \end{array}$$

$k = 2$

rank of green  
 $\leq \#\star$ 's in green = 0

# Tilted Richardson Varieties

For  $u, v \in S_n$  and a sequence  $\mathbf{a} = (a_1, \dots, a_{n-1}) \in [n]^{n-1}$ , we define the **tilted Richardson variety/cell**  $\mathcal{T}_{u,v,\mathbf{a}}$  (and  $\mathcal{T}_{u,v,\mathbf{a}}^\circ$ ) in  $\mathbb{F}l_n$  as follows.

## Example

Consider  $u = 4321(\star)$ ,  $v = 3142(\bullet)$ , and  $\mathbf{a} = (4, 2, 2)(-)$ .

Rank conditions in the left  $k$  columns for each  $k \in \{1, 2, 3\}$ . When  $k = 2$ :

Start from the row below red line and go down:

$$M = \begin{array}{|c|c|c|c|} \hline & \bullet & & \star & 1 \\ \hline \color{green}\square & \color{green}\square & \color{green}\square & \star & 2 \\ \hline \bullet & \star & & & 3 \\ \hline \star & & \bullet & & 4 \\ \hline \end{array}$$

$k = 2$

rank of green  
 $\leq \#\star$ 's in green = 1

# Tilted Richardson Varieties

For  $u, v \in S_n$  and a sequence  $\mathbf{a} = (a_1, \dots, a_{n-1}) \in [n]^{n-1}$ , we define the **tilted Richardson variety/cell**  $\mathcal{T}_{u,v,\mathbf{a}}$  (and  $\mathcal{T}_{u,v,\mathbf{a}}^\circ$ ) in  $\mathbb{F}l_n$  as follows.

## Example

Consider  $u = 4321(\star)$ ,  $v = 3142(\bullet)$ , and  $\mathbf{a} = (4, 2, 2)(-)$ .

Rank conditions in the left  $k$  columns for each  $k \in \{1, 2, 3\}$ . When  $k = 2$ :

Start from the row below red line and go down:

$$M = \begin{array}{cccc|c} & & \bullet & & \star & 1 \\ \hline & & & & & 2 \\ \hline & & & & \star & \bullet & 2 \\ & & \bullet & \star & & & 3 \\ \hline & & & & & & 4 \\ & & \star & & \bullet & & 4 \end{array}$$

$k = 2$

rank of green  
 $\leq \#\star$ 's in green = 2

# Tilted Richardson Varieties

For  $u, v \in S_n$  and a sequence  $\mathbf{a} = (a_1, \dots, a_{n-1}) \in [n]^{n-1}$ , we define the **tilted Richardson variety/cell**  $\mathcal{T}_{u,v,\mathbf{a}}$  (and  $\mathcal{T}_{u,v,\mathbf{a}}^\circ$ ) in  $\mathbb{F}l_n$  as follows.

## Example

Consider  $u = 4321(\star)$ ,  $v = 3142(\bullet)$ , and  $\mathbf{a} = (4, 2, 2)(-)$ .

Rank conditions in the left  $k$  columns for each  $k \in \{1, 2, 3\}$ . When  $k = 2$ :

Start from the row above red line and go up:

$$M = \begin{array}{cccc|c} \text{yellow} & \bullet & & \star & 1 \\ \hline & & \star & \bullet & 2 \\ \bullet & \star & & & 3 \\ \hline \star & & \bullet & & 4 \end{array}$$

$k = 2$

rank of yellow  
 $\leq \# \bullet$ 's in yellow = 1

# Tilted Richardson Varieties

For  $u, v \in S_n$  and a sequence  $\mathbf{a} = (a_1, \dots, a_{n-1}) \in [n]^{n-1}$ , we define the **tilted Richardson variety/cell**  $\mathcal{T}_{u,v,\mathbf{a}}$  (and  $\mathcal{T}_{u,v,\mathbf{a}}^\circ$ ) in  $\mathbb{F}l_n$  as follows.

## Example

Consider  $u = 4321(\star)$ ,  $v = 3142(\bullet)$ , and  $\mathbf{a} = (4, 2, 2)(-)$ .

Rank conditions in the left  $k$  columns for each  $k \in \{1, 2, 3\}$ . When  $k = 2$ :

Start from the row above red line and go up (cyclically):

$$M = \begin{array}{cccc|c} \text{yellow} & \bullet & & \star & 1 \\ \hline & & \star & \bullet & 2 \\ \bullet & \star & & & 3 \\ \hline \star & \text{yellow} & \bullet & & 4 \end{array} \quad \begin{array}{l} \text{rank of yellow} \\ \leq \# \bullet\text{'s in yellow} = 1 \end{array}$$

$k = 2$

# Tilted Richardson Varieties

For  $u, v \in S_n$  and a sequence  $\mathbf{a} = (a_1, \dots, a_{n-1}) \in [n]^{n-1}$ , we define the **tilted Richardson variety/cell**  $\mathcal{T}_{u,v,\mathbf{a}}$  (and  $\mathcal{T}_{u,v,\mathbf{a}}^\circ$ ) in  $\mathbb{F}l_n$  as follows.

## Example

Consider  $u = 4321(\star)$ ,  $v = 3142(\bullet)$ , and  $\mathbf{a} = (4, 2, 2)(-)$ .

Rank conditions in the left  $k$  columns for each  $k \in \{1, 2, 3\}$ . When  $k = 2$ :

Start from the row above red line and go up (cyclically):

$$M = \begin{array}{cccc|c} \text{yellow} & \bullet & & \star & 1 \\ \hline & & \star & \bullet & 2 \\ \text{yellow} & \star & & & 3 \\ \hline \star & \text{yellow} & \bullet & & 4 \end{array}$$

$k = 2$

rank of yellow  
 $\leq \# \bullet$ 's in yellow = 2

# Tilted Richardson Varieties

For  $u, v \in S_n$  and a sequence  $\mathbf{a} = (a_1, \dots, a_{n-1}) \in [n]^{n-1}$ , we define the **tilted Richardson variety/cell**  $\mathcal{T}_{u,v,\mathbf{a}}$  (and  $\mathcal{T}_{u,v,\mathbf{a}}^\circ$ ) in  $\mathbb{F}l_n$  as follows.

## Example

Consider  $u = 4321(\star)$ ,  $v = 3142(\bullet)$ , and  $\mathbf{a} = (4, 2, 2)(-)$ .

Rank conditions in the left  $k$  columns for each  $k \in \{1, 2, 3\}$ . When  $k = 2$ :

Start from the row above red line and go up (cyclically):

$$M = \begin{array}{|c|c|c|c|} \hline \text{yellow} & \bullet & & \star \\ \hline & & \star & \bullet \\ \hline \bullet & \star & & \\ \hline \star & \text{yellow} & \bullet & \\ \hline \end{array} \begin{array}{l} 1 \\ 2 \\ 3 \\ 4 \end{array}$$

$k = 2$

rank of yellow  
 $\leq \# \bullet$ 's in yellow = 2

Replacing " $\leq$ " with " $=$ " gives us rank conditions for  $\mathcal{T}_{u,v,\mathbf{a}}^\circ$ .

# Tilted Richardson Varieties

We defined  $\mathcal{T}_{u,v,a}$  as a closed subvariety of  $\text{Fl}_n$ , and  $\mathcal{T}_{u,v,a}^\circ \subseteq \mathcal{T}_{u,v,a}$  as an open subset. However, sometimes  $\mathcal{T}_{u,v,a}$  (and  $\mathcal{T}_{u,v,a}^\circ$ ) are empty.

# Tilted Richardson Varieties

We defined  $\mathcal{T}_{u,v,a}$  as a closed subvariety of  $\mathbb{F}l_n$ , and  $\mathcal{T}_{u,v,a}^\circ \subseteq \mathcal{T}_{u,v,a}$  as an open subset. However, sometimes  $\mathcal{T}_{u,v,a}$  (and  $\mathcal{T}_{u,v,a}^\circ$ ) are empty.

## Theorem (G.-Gao-Gao '23)

For  $u, v \in S_n$ , the variety  $\mathcal{T}_{u,v,a}$  (and  $\mathcal{T}_{u,v,a}^\circ$ )

- is **nonempty** iff  $\underline{u \leq_a v}$  (an explicit combinatorial criterion);

# Tilted Richardson Varieties

We defined  $\mathcal{T}_{u,v,\mathbf{a}}$  as a closed subvariety of  $\mathrm{Fl}_n$ , and  $\mathcal{T}_{u,v,\mathbf{a}}^\circ \subseteq \mathcal{T}_{u,v,\mathbf{a}}$  as an open subset. However, sometimes  $\mathcal{T}_{u,v,\mathbf{a}}$  (and  $\mathcal{T}_{u,v,\mathbf{a}}^\circ$ ) are empty.

## Theorem (G.-Gao-Gao '23)

For  $u, v \in S_n$ , the variety  $\mathcal{T}_{u,v,\mathbf{a}}$  (and  $\mathcal{T}_{u,v,\mathbf{a}}^\circ$ )

- is **nonempty** iff  $u \leq_{\mathbf{a}} v$  (an explicit combinatorial criterion);
- has at least one choice of  $\mathbf{a}$  that makes it nonempty;

# Tilted Richardson Varieties

We defined  $\mathcal{T}_{u,v,\mathbf{a}}$  as a closed subvariety of  $\mathbb{F}l_n$ , and  $\mathcal{T}_{u,v,\mathbf{a}}^\circ \subseteq \mathcal{T}_{u,v,\mathbf{a}}$  as an open subset. However, sometimes  $\mathcal{T}_{u,v,\mathbf{a}}$  (and  $\mathcal{T}_{u,v,\mathbf{a}}^\circ$ ) are empty.

## Theorem (G.-Gao-Gao '23)

For  $u, v \in S_n$ , the variety  $\mathcal{T}_{u,v,\mathbf{a}}$  (and  $\mathcal{T}_{u,v,\mathbf{a}}^\circ$ )

- is **nonempty** iff  $u \leq_{\mathbf{a}} v$  (an explicit combinatorial criterion);
- has at least one choice of  $\mathbf{a}$  that makes it nonempty;
- is **independent** of  $\mathbf{a}$  when it is nonempty.

# Tilted Richardson Varieties

We defined  $\mathcal{T}_{u,v,\mathbf{a}}$  as a closed subvariety of  $\mathbb{F}l_n$ , and  $\mathcal{T}_{u,v,\mathbf{a}}^\circ \subseteq \mathcal{T}_{u,v,\mathbf{a}}$  as an open subset. However, sometimes  $\mathcal{T}_{u,v,\mathbf{a}}$  (and  $\mathcal{T}_{u,v,\mathbf{a}}^\circ$ ) are empty.

## Theorem (G.-Gao-Gao '23)

For  $u, v \in S_n$ , the variety  $\mathcal{T}_{u,v,\mathbf{a}}$  (and  $\mathcal{T}_{u,v,\mathbf{a}}^\circ$ )

- is **nonempty** iff  $u \leq_{\mathbf{a}} v$  (an explicit combinatorial criterion);
- has at least one choice of  $\mathbf{a}$  that makes it nonempty;
- is **independent** of  $\mathbf{a}$  when it is nonempty.

Therefore, we denote this nonempty space as  $\mathcal{T}_{u,v}$  (and  $\mathcal{T}_{u,v}^\circ$ ).

# Tilted Richardson Varieties

We defined  $\mathcal{T}_{u,v,\mathbf{a}}$  as a closed subvariety of  $\mathrm{Fl}_n$ , and  $\mathcal{T}_{u,v,\mathbf{a}}^\circ \subseteq \mathcal{T}_{u,v,\mathbf{a}}$  as an open subset. However, sometimes  $\mathcal{T}_{u,v,\mathbf{a}}$  (and  $\mathcal{T}_{u,v,\mathbf{a}}^\circ$ ) are empty.

## Theorem (G.-Gao-Gao '23)

For  $u, v \in S_n$ , the variety  $\mathcal{T}_{u,v,\mathbf{a}}$  (and  $\mathcal{T}_{u,v,\mathbf{a}}^\circ$ )

- is **nonempty** iff  $u \leq_{\mathbf{a}} v$  (an explicit combinatorial criterion);
- has at least one choice of  $\mathbf{a}$  that makes it nonempty;
- is **independent** of  $\mathbf{a}$  when it is nonempty.

Therefore, we denote this nonempty space as  $\mathcal{T}_{u,v}$  (and  $\mathcal{T}_{u,v}^\circ$ ).

Note: If  $u \leq v$  in Bruhat order,  $\mathcal{T}_{u,v} = \mathcal{R}_{u,v}$  is the Richardson variety,  $\mathcal{T}_{u,v}^\circ = \mathcal{R}_{u,v}^\circ$  is the Richardson cell.

# Main Theorem

## Theorem (G.-Gao-Gao '23 '24+)

- (*Torus fixed points*) A  $T$ -fixed point  $wB \in \mathcal{T}_{u,v} \iff w \in [u, v]_q,$

# Main Theorem

## Theorem (G.-Gao-Gao '23 '24+)

- (Torus fixed points) A  $T$ -fixed point  $wB \in \mathcal{T}_{u,v} \iff w \in [u, v]_q$ ,
- (Dimension)  $\mathcal{T}_{u,v}$  and  $\mathcal{T}_{u,v}^\circ$  are equi-dimensional of  $\dim \ell(u, v)$ ,  
here  $\ell(u, v) :=$  length of the shortest path  $u \rightarrow v$  in  $\Gamma_n$ ,

# Main Theorem

## Theorem (G.-Gao-Gao '23 '24+)

- (Torus fixed points) A  $T$ -fixed point  $wB \in \mathcal{T}_{u,v} \iff w \in [u, v]_q$ ,
- (Dimension)  $\mathcal{T}_{u,v}$  and  $\mathcal{T}_{u,v}^\circ$  are equi-dimensional of  $\dim \ell(u, v)$ ,  
here  $\ell(u, v) :=$  length of the shortest path  $u \rightarrow v$  in  $\Gamma_n$ ,
- (Stratification)  $\mathcal{T}_{u,v} = \bigsqcup_{[x,y]_q \subseteq [u,v]_q} \mathcal{T}_{x,y}^\circ$  and  $\mathcal{T}_{u,v} = \overline{\mathcal{T}_{u,v}^\circ}$ ,

# Main Theorem

## Theorem (G.-Gao-Gao '23 '24+)

- (Torus fixed points) A  $T$ -fixed point  $wB \in \mathcal{T}_{u,v} \iff w \in [u, v]_q$ ,
- (Dimension)  $\mathcal{T}_{u,v}$  and  $\mathcal{T}_{u,v}^\circ$  are equi-dimensional of  $\dim \ell(u, v)$ ,  
here  $\ell(u, v) :=$  length of the shortest path  $u \rightarrow v$  in  $\Gamma_n$ ,
- (Stratification)  $\mathcal{T}_{u,v} = \bigsqcup_{[x,y]_q \subseteq [u,v]_q} \mathcal{T}_{x,y}^\circ$  and  $\mathcal{T}_{u,v} = \overline{\mathcal{T}_{u,v}^\circ}$ ,
- (Irreducibility)  $\mathcal{T}_{u,v}$  is irreducible,

# Main Theorem

## Theorem (G.-Gao-Gao '23 '24+)

- (Torus fixed points) A  $T$ -fixed point  $wB \in \mathcal{T}_{u,v} \iff w \in [u, v]_q$ ,
- (Dimension)  $\mathcal{T}_{u,v}$  and  $\mathcal{T}_{u,v}^\circ$  are equi-dimensional of  $\dim \ell(u, v)$ ,  
here  $\ell(u, v) :=$  length of the shortest path  $u \rightarrow v$  in  $\Gamma_n$ ,
- (Stratification)  $\mathcal{T}_{u,v} = \bigsqcup_{[x,y]_q \subseteq [u,v]_q} \mathcal{T}_{x,y}^\circ$  and  $\mathcal{T}_{u,v} = \overline{\mathcal{T}_{u,v}^\circ}$ ,
- (Irreducibility)  $\mathcal{T}_{u,v}$  is irreducible,
- $\mathcal{T}_{u,v}$  is the curve neighbourhood  $\Gamma_{d_{\min}}(X^u, X_v)$ ,

# Main Theorem

## Theorem (G.-Gao-Gao '23 '24+)

- (Torus fixed points) A  $T$ -fixed point  $wB \in \mathcal{T}_{u,v} \iff w \in [u, v]_q$ ,
- (Dimension)  $\mathcal{T}_{u,v}$  and  $\mathcal{T}_{u,v}^\circ$  are equi-dimensional of  $\dim \ell(u, v)$ ,  
here  $\ell(u, v) :=$  length of the shortest path  $u \rightarrow v$  in  $\Gamma_n$ ,
- (Stratification)  $\mathcal{T}_{u,v} = \bigsqcup_{[x,y]_q \subseteq [u,v]_q} \mathcal{T}_{x,y}^\circ$  and  $\mathcal{T}_{u,v} = \overline{\mathcal{T}_{u,v}^\circ}$ ,
- (Irreducibility)  $\mathcal{T}_{u,v}$  is irreducible,
- $\mathcal{T}_{u,v}$  is the curve neighbourhood  $\Gamma_{d_{\min}}(X^u, X_v)$ ,
- $[\mathcal{T}_{u,v}] = [\Gamma_{d_{\min}}(X^u, X_v)] = [q^{d_{\min}}] \sigma_u \star \sigma_{w_0 v} \in H^*(\mathbb{F}l_n)$  (i.e.  $c = 1$ ).

# Main Theorem

## Theorem (G.-Gao-Gao '23 '24+)

- (Torus fixed points) A T-fixed point  $wB \in \mathcal{T}_{u,v} \iff w \in [u, v]_q$ ,
- (Dimension)  $\mathcal{T}_{u,v}$  and  $\mathcal{T}_{u,v}^\circ$  are equi-dimensional of  $\dim \ell(u, v)$ ,  
here  $\ell(u, v) :=$  length of the shortest path  $u \rightarrow v$  in  $\Gamma_n$ ,
- (Stratification)  $\mathcal{T}_{u,v} = \bigsqcup_{[x,y]_q \subseteq [u,v]_q} \mathcal{T}_{x,y}^\circ$  and  $\mathcal{T}_{u,v} = \overline{\mathcal{T}_{u,v}^\circ}$ ,
- (Irreducibility)  $\mathcal{T}_{u,v}$  is irreducible,  $\Leftarrow$  **Deodhar decomposition**
- $\mathcal{T}_{u,v}$  is the curve neighbourhood  $\Gamma_{d_{\min}}(X^u, X_v)$ ,  $\Leftarrow (*)$
- $[\mathcal{T}_{u,v}] = [\Gamma_{d_{\min}}(X^u, X_v)] = [q^{d_{\min}}\sigma_u \star \sigma_{w_0v}] \in H^*(\mathbb{F}l_n)$  (i.e.  $c = 1$ ).

### Proof idea for (\*):

- 1 First show that both varieties have same set of T-fixed points  $[u, v]_q$ ;
- 2 Then show that  $\mathcal{T}_{u,v}$  is the largest T-fixed variety with T-fixed points  $[u, v]_q$ ,  
so  $\mathcal{T}_{u,v} \supseteq \Gamma_{d_{\min}}(X^u, X_v)$ ;
- 3 Finally, both varieties have the same dimension and  $\mathcal{T}_{u,v}$  is irreducible.

# A summary

Classical	Quantum
$H^*(\mathbb{F}l_n)$	$QH^*(\mathbb{F}l_n)$
(Strong) Bruhat Order $S_n$	Quantum Bruhat Graph $\Gamma_n$
Bruhat Interval $[u, v]$	Tilted Bruhat Interval $[u, v]_q$
Schubert Variety $X_w$	
Richardson Variety $\mathcal{R}_{u,v}/\mathcal{R}_{u,v}^\circ$	Tilted Richardson $\mathcal{T}_{u,v}/\mathcal{T}_{u,v}^\circ$
Deodhar Decomposition of $\mathcal{R}_{u,v}^\circ$	Deodhar Decomposition of $\mathcal{T}_{u,v}^\circ$
Totally Nonnegative part $\mathcal{R}_{u,v}^{>0}$	Totally Nonnegative part $\mathcal{T}_{u,v}^{>0}$
R polynomial	Tilted R polynomial

# Deodhar decomposition

Motivation: Given a pair of permutations  $u \leq v$ , the **Kazhdan-Lusztig R polynomial** in variable  $q$  is defined as the  $\mathbb{F}_q$ -point count of the Richardson cell  $\mathcal{R}_{u,v}^\circ$ :

$$R_{u,v}(q) := \#\mathcal{R}_{u,v}^\circ(\mathbb{F}_q).$$

They are elementary pieces used to construct the **Kazhdan-Lusztig polynomials**  $P_{u,v}(q)$ , which plays a fundamental role in representation theory.

# Deodhar decomposition

Motivation: Given a pair of permutations  $u \leq v$ , the **Kazhdan-Lusztig R polynomial** in variable  $q$  is defined as the  $\mathbb{F}_q$ -point count of the Richardson cell  $\mathcal{R}_{u,v}^\circ$ :

$$R_{u,v}(q) := \#\mathcal{R}_{u,v}^\circ(\mathbb{F}_q).$$

They are elementary pieces used to construct the **Kazhdan-Lusztig polynomials**  $P_{u,v}(q)$ , which plays a fundamental role in representation theory.

Main idea: In order to understand  $R_{u,v}(q)$ , Deodhar ('85) introduced **Deodhar decomposition**, which decomposes the Richardson cell  $\mathcal{R}_{u,v}^\circ$  into **simple pieces** that are isomorphic to  $\mathbb{C}^a \times (\mathbb{C}^*)^b$ .

$$\mathcal{R}_{u,v}^\circ = \bigsqcup_{\alpha} \mathbb{C}^a \times (\mathbb{C}^*)^b \implies R_{u,v}(q) = \sum_{\alpha} q^a (q-1)^b.$$

# Deodhar decomposition

Theorem (Deodhar '85, Marsh-Rietsch '03)

The Richardson cell  $\mathcal{R}_{u,v}^\circ$  can be decomposed into **Deodhar cells**  $D_\alpha$ :

$$\mathcal{R}_{u,v}^\circ = \bigsqcup_{\alpha} D_\alpha, \text{ where each } D_\alpha \cong (\mathbb{C}^*)^{p(\alpha)} \times \mathbb{C}^{q(\alpha)}$$

Each Deodhar cell  $D_\alpha$  can be explicitly parametrized by products of elementary matrices  $y_i(p)$ ,  $x_i(m)$  and  $\dot{s}_j$ .

# Deodhar decomposition

## Theorem (Deodhar '85, Marsh-Rietsch '03)

The Richardson cell  $\mathcal{R}_{u,v}^\circ$  can be decomposed into **Deodhar cells**  $D_\alpha$ :

$$\mathcal{R}_{u,v}^\circ = \bigsqcup_{\alpha} D_\alpha, \text{ where each } D_\alpha \cong (\mathbb{C}^*)^{p(\alpha)} \times \mathbb{C}^{q(\alpha)}$$

Each Deodhar cell  $D_\alpha$  can be explicitly parametrized by products of elementary matrices  $y_i(p)$ ,  $x_i(m)$  and  $\dot{s}_j$ .

## Theorem (G.-Gao-Gao '24+)

The tilted Richardson cell  $\mathcal{T}_{u,v}^\circ$  can be decomposed into **tilted Deodhar cells**  $D_\beta$  that are explicitly parametrizable:

$$\mathcal{T}_{u,v}^\circ = \bigsqcup_{\beta} D_\beta, \text{ where each } D_\beta \cong (\mathbb{C}^*)^{p(\beta)} \times \mathbb{C}^{q(\beta)}$$

# Proof of irreducibility

# Proof of irreducibility

## Theorem (G.-Gao-Gao '24+)

*In the Deodhar decomposition of  $\mathcal{T}_{u,v}^\circ = \bigsqcup_{\beta} D_{\beta}$ , there exists a **unique tilted Deodhar cell of maximal dimension**  $D_{\beta_+} \cong (\mathbb{C}^*)^{\ell(u,v)}$ , and all other cells  $D_{\beta}$  have dimension  $< \ell(u,v)$ .*

# Proof of irreducibility

## Theorem (G.-Gao-Gao '24+)

In the Deodhar decomposition of  $\mathcal{T}_{u,v}^\circ = \bigsqcup_{\beta} D_{\beta}$ , there exists a **unique tilted Deodhar cell of maximal dimension**  $D_{\beta_+} \cong (\mathbb{C}^*)^{\ell(u,v)}$ , and all other cells  $D_{\beta}$  have dimension  $< \ell(u,v)$ .

Theorem above +  $\dim(\mathcal{T}_{u,v}) = \ell(u,v)$  equi-dimensional  $\implies$

## Corollary (G.-Gao-Gao '24+)

$\mathcal{T}_{u,v}$  is irreducible, and  $D_{\beta_+} \subset \mathcal{T}_{u,v}$  is a dense subset.

# Total Positivity

# Total Positivity

## Theorem (Björner '84, Dyer '93)

*If a poset is thin and EL-shellable, then the poset is the face poset of a regular CW-complex.*

## Theorem (Brenti-Fomin-Postnikov '99)

*The tilted Bruhat interval  $[u, v]_q$  is thin and EL-shellable.*

# Total Positivity

## Theorem (Björner '84, Dyer '93)

*If a poset is thin and EL-shellable, then the poset is the face poset of a regular CW-complex.*

## Theorem (Brenti-Fomin-Postnikov '99)

*The tilted Bruhat interval  $[u, v]_q$  is thin and EL-shellable.*

**Q: Can one find a natural realization of such CW-complex?**

# Total Positivity

## Theorem (Björner '84, Dyer '93)

*If a poset is thin and EL-shellable, then the poset is the face poset of a regular CW-complex.*

## Theorem (Brenti-Fomin-Postnikov '99)

*The tilted Bruhat interval  $[u, v]_q$  is thin and EL-shellable.*

Q: Can one find a natural realization of such CW-complex?

⇒ Total Nonnegative part of  $T_{u,v}$

# Total Positivity

## Definition (G.-Gao-Gao '24+)

For a sequence  $\mathbf{a} = (a_1, \dots, a_{n-1}) \in [n]^{n-1}$ , the **tilted totally nonnegative flag variety**  $\text{TNN}_{\mathbf{a}} \subset \text{Fl}_n(\mathbb{R})$  is the set of all flags  $gB$  whose Plücker coordinates satisfy

$$\Delta_{i_1, \dots, i_k}(g) \geq 0, \text{ for any } i_1 <_{a_k} i_2 <_{a_k} \dots <_{a_k} i_k, \forall k$$

under the shifted total order  $<_{a_k}$ .

# Total Positivity

## Definition (G.-Gao-Gao '24+)

For a sequence  $\mathbf{a} = (a_1, \dots, a_{n-1}) \in [n]^{n-1}$ , the **tilted totally nonnegative flag variety**  $\text{TNN}_{\mathbf{a}} \subset \text{Fl}_n(\mathbb{R})$  is the set of all flags  $gB$  whose Plücker coordinates satisfy

$$\Delta_{i_1, \dots, i_k}(g) \geq 0, \text{ for any } i_1 <_{a_k} i_2 <_{a_k} \dots <_{a_k} i_k, \forall k$$

under the shifted total order  $<_{a_k}$ .

If  $n = 4$ ,  $\mathbf{a} = (4, 3, 2)$ , then flags in  $\text{TNN}_{\mathbf{a}}$  satisfies:

$$\begin{aligned} \Delta_4, \Delta_1, \Delta_2, \Delta_3 &\geq 0 \\ \Delta_{34}, \Delta_{31}, \Delta_{32}, \Delta_{41}, \Delta_{42}, \Delta_{12} &\geq 0 \\ \Delta_{234}, \Delta_{231}, \Delta_{241}, \Delta_{341} &\geq 0 \end{aligned}$$

# Total Positivity

## Definition (G.-Gao-Gao '24+)

Define the **TNN part of tilted Richardson cell/variety** to be  $\mathcal{T}_{u,v}^{>0} := \mathcal{T}_{u,v}^{\circ} \cap \text{TNN}_{\mathbf{a}}$  and  $\mathcal{T}_{u,v}^{\geq 0} := \mathcal{T}_{u,v} \cap \text{TNN}_{\mathbf{a}}$  for any  $\mathbf{a}$  such that  $\mathcal{T}_{u,v,\mathbf{a}} \neq \emptyset$ . This definition is independent of the choice of  $\mathbf{a}$ .

# Total Positivity

## Definition (G.-Gao-Gao '24+)

Define the **TNN part of tilted Richardson cell/variety** to be  $\mathcal{T}_{u,v}^{>0} := \mathcal{T}_{u,v}^\circ \cap \text{TNN}_{\mathbf{a}}$  and  $\mathcal{T}_{u,v}^{\geq 0} := \mathcal{T}_{u,v} \cap \text{TNN}_{\mathbf{a}}$  for any  $\mathbf{a}$  such that  $\mathcal{T}_{u,v,\mathbf{a}} \neq \emptyset$ . This definition is independent of the choice of  $\mathbf{a}$ .

## Conjecture (G.-Gao-Gao '24+)

$\mathcal{T}_{u,v}^{>0}$  is homeomorphic to a ball.

# Total Positivity

## Definition (G.-Gao-Gao '24+)

Define the **TNN part of tilted Richardson cell/variety** to be  $\mathcal{T}_{u,v}^{>0} := \mathcal{T}_{u,v}^{\circ} \cap \text{TNN}_{\mathbf{a}}$  and  $\mathcal{T}_{u,v}^{\geq 0} := \mathcal{T}_{u,v} \cap \text{TNN}_{\mathbf{a}}$  for any  $\mathbf{a}$  such that  $\mathcal{T}_{u,v,\mathbf{a}} \neq \emptyset$ . This definition is independent of the choice of  $\mathbf{a}$ .

## Conjecture (G.-Gao-Gao '24+)

$\mathcal{T}_{u,v}^{>0}$  is homeomorphic to a ball.

## Conjecture (G.-Gao-Gao '24+)

$\mathcal{T}_{u,v}^{\geq 0} = \bigsqcup_{[x,y]_q \subseteq [u,v]_q} \mathcal{T}_{x,y}^{>0}$  is a (regular) CW-complex.

# Tilted $R$ polynomial

# Tilted R polynomial

Recall the R polynomial is defined as

$$R_{u,v}(q) := \#\mathcal{R}_{u,v}^{\circ}(\mathbb{F}_q).$$

## Combinatorial Invariance Problem (Lusztig '83, Dyer '87)

The Kazhdan-Lusztig R polynomial  $R_{u,v}(q)$  depends only on the poset structure of the strong Bruhat interval  $[u, v]$ .

# Tilted R polynomial

Recall the R polynomial is defined as

$$R_{u,v}(q) := \#\mathcal{R}_{u,v}^\circ(\mathbb{F}_q).$$

## Combinatorial Invariance Problem (Lusztig '83, Dyer '87)

The Kazhdan-Lusztig R polynomial  $R_{u,v}(q)$  depends only on the poset structure of the strong Bruhat interval  $[u, v]$ .

The **tilted R polynomial** is defined as

$$R_{u,v}^{\text{tilt}}(q) := \#\mathcal{T}_{u,v}^\circ(\mathbb{F}_q).$$

We can use Deodhar decomposition to compute these polynomials.

# Tilted R polynomial

Recall the R polynomial is defined as

$$R_{u,v}(q) := \#\mathcal{R}_{u,v}^\circ(\mathbb{F}_q).$$

## Combinatorial Invariance Problem (Lusztig '83, Dyer '87)

The Kazhdan-Lusztig R polynomial  $R_{u,v}(q)$  depends only on the poset structure of the strong Bruhat interval  $[u, v]$ .

The **tilted R polynomial** is defined as

$$R_{u,v}^{\text{tilt}}(q) := \#\mathcal{T}_{u,v}^\circ(\mathbb{F}_q).$$

We can use Deodhar decomposition to compute these polynomials.

## Conjecture (G.-Gao-Gao '24+)

$R_{u,v}^{\text{tilt}}(q)$  depends only on the poset structure of the tilted Bruhat interval  $[u, v]_q$ .

Thank you all for listening!

Part 1: arXiv:2309.01309

Part 2: in progress

# A Simple Formula for $q^{d_{\min}}$

## Theorem (G.-Gao-Gao '23)

For  $u, v \in S_n$ , the weight of any shortest path  $u \rightarrow v$  in  $\Gamma_n$  is  $q_1^{d_1} \cdots q_{n-1}^{d_{n-1}}$ , where  $d_k = \text{depth of the lattice path } P(u[k], v[k]) \text{ formed by using } u[k] := \{u_1, \dots, u_k\} \text{ as upsteps and } v[k] := \{v_1, \dots, v_k\} \text{ as downsteps.}$

# A Simple Formula for $q^{d_{\min}}$

## Theorem (G.-Gao-Gao '23)

For  $u, v \in S_n$ , the weight of any shortest path  $u \rightarrow v$  in  $\Gamma_n$  is  $q_1^{d_1} \cdots q_{n-1}^{d_{n-1}}$ , where  $d_k = \text{depth of the lattice path } P(u[k], v[k]) \text{ formed by using } u[k] := \{u_1, \dots, u_k\} \text{ as upsteps and } v[k] := \{v_1, \dots, v_k\} \text{ as downsteps.}$

## Example

For  $u = 4637521$ ,  $v = 5312467$  and  $k = 4$ , upsteps  $u[k] = \{3, 4, 6, 7\}$  and downsteps  $v[k] = \{1, 2, 3, 5\}$ . We have  $d_k = \text{depth} = 2$ .

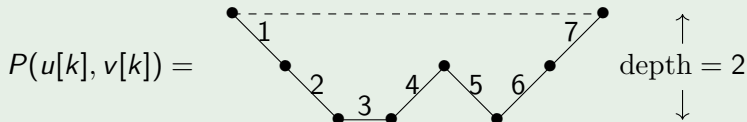

In total,  $q^{d_{\min}} = q_2 q_3 q_4^2 q_5^2 q_6$ .

## Criteria for $T_{u,v,a} \neq \emptyset$

For  $a \in [n]$ , let  $\leq_a$  be the **shifted total order** of  $[n]$  where

$$a <_a a + 1 <_a \cdots <_a n <_a 1 <_a \cdots <_a a - 1.$$

## Criteria for $T_{u,v,a} \neq \emptyset$

For  $a \in [n]$ , let  $\leq_a$  be the **shifted total order** of  $[n]$  where

$$a <_a a + 1 <_a \cdots <_a n <_a 1 <_a \cdots <_a a - 1.$$

For  $I = \{i_1 \leq_a \cdots \leq_a i_k\}$ ,  $J = \{j_1 \leq_a \cdots \leq_a j_k\} \in \binom{[n]}{k}$ , we say  $I \leq_a J$  if

$$i_m \leq_a j_m \text{ for all } m \in [k].$$

## Criteria for $T_{u,v,\mathbf{a}} \neq \emptyset$

For  $a \in [n]$ , let  $\leq_a$  be the **shifted total order** of  $[n]$  where

$$a <_a a + 1 <_a \cdots <_a n <_a 1 <_a \cdots <_a a - 1.$$

For  $I = \{i_1 \leq_a \cdots \leq_a i_k\}$ ,  $J = \{j_1 \leq_a \cdots \leq_a j_k\} \in \binom{[n]}{k}$ , we say  $I \leq_a J$  if

$$i_m \leq_a j_m \text{ for all } m \in [k].$$

For  $u, v \in S_n$  and a sequence  $\mathbf{a} = (a_1, \dots, a_{n-1})$ , we say  $u \leq_{\mathbf{a}} v$  if

$$u[k] := \{u_1, \dots, u_k\} \leq_{a_k} v[k] \text{ for all } k \in [n-1].$$

## Criteria for $\mathcal{T}_{u,v,\mathbf{a}} \neq \emptyset$

For  $a \in [n]$ , let  $\leq_a$  be the **shifted total order** of  $[n]$  where

$$a <_a a+1 <_a \cdots <_a n <_a 1 <_a \cdots <_a a-1.$$

For  $I = \{i_1 \leq_a \cdots \leq_a i_k\}$ ,  $J = \{j_1 \leq_a \cdots \leq_a j_k\} \in \binom{[n]}{k}$ , we say  $I \leq_a J$  if

$$i_m \leq_a j_m \text{ for all } m \in [k].$$

For  $u, v \in S_n$  and a sequence  $\mathbf{a} = (a_1, \dots, a_{n-1})$ , we say  $u \leq_a v$  if

$$u[k] := \{u_1, \dots, u_k\} \leq_{a_k} v[k] \text{ for all } k \in [n-1].$$

### Theorem (G.-Gao-Gao '23)

$\mathcal{T}_{u,v,\mathbf{a}}$  and  $\mathcal{T}_{u,v,\mathbf{a}}^\circ$  are nonempty  $\iff u \leq_a v$ .

## Criteria for $\mathcal{T}_{u,v,\mathbf{a}} \neq \emptyset$

For  $a \in [n]$ , let  $\leq_a$  be the **shifted total order** of  $[n]$  where

$$a <_a a+1 <_a \cdots <_a n <_a 1 <_a \cdots <_a a-1.$$

For  $I = \{i_1 \leq_a \cdots \leq_a i_k\}$ ,  $J = \{j_1 \leq_a \cdots \leq_a j_k\} \in \binom{[n]}{k}$ , we say  $I \leq_a J$  if

$$i_m \leq_a j_m \text{ for all } m \in [k].$$

For  $u, v \in S_n$  and a sequence  $\mathbf{a} = (a_1, \dots, a_{n-1})$ , we say  $u \leq_a v$  if

$$u[k] := \{u_1, \dots, u_k\} \leq_{a_k} v[k] \text{ for all } k \in [n-1].$$

### Theorem (G.-Gao-Gao '23)

$\mathcal{T}_{u,v,\mathbf{a}}$  and  $\mathcal{T}_{u,v,\mathbf{a}}^\circ$  are nonempty  $\iff u \leq_a v$ .

### Theorem (G.-Gao-Gao '23)

if  $u \leq_a v$ , then the posets  $[u, v]_{\leq_a} = [u, v]_q$ .

# Tilted Deodhar decomposition

## Definition (G.-Gao-Gao '24+)

Fix a tilted reduced word  $\mathbf{v} = s_{i_1} s_{i_2} \cdots s_{i_\ell}$  of  $v$ . A **tilted distinguished subword** for  $u$  is  $\mathbf{u} = u_1 \cdots u_\ell$  where each  $u_k \in \{1, s_{i_k}, s_{i_k}, s_{i_k}\}$  that follows certain rules and their product is  $u$ . We denote  $\mathbf{u} \prec_t \mathbf{v}$ .

# Tilted Deodhar decomposition

## Definition (G.-Gao-Gao '24+)

Fix a tilted reduced word  $\mathbf{v} = s_{i_1} s_{i_2} \cdots s_{i_\ell}$  of  $v$ . A **tilted distinguished subword** for  $u$  is  $\mathbf{u} = u_1 \cdots u_\ell$  where each  $u_k \in \{1, s_{i_k}, s_{i_k}^{\text{red}}, s_{i_k}^{\text{blue}}\}$  that follows certain rules and their product is  $u$ . We denote  $\mathbf{u} \prec_t \mathbf{v}$ .

## Example

For  $u = 512346$  and  $v = 246513$ , given a tilted reduced word  $\mathbf{v} = s_3 s_4 s_5 s_1 s_2 s_3 s_4 s_3 s_2 s_1 s_1 s_2$ , there are 4 tilted distinguished subwords:

$$\mathbf{u} = 11111s_4s_3s_2s_111$$

$$\mathbf{u} = 111s_111s_4s_3s_2s_1s_2$$

$$\mathbf{u} = s_31111s_3s_4s_3s_2s_111$$

$$\mathbf{u} = s_311s_11s_3s_4s_3s_2s_1s_2$$

# Tilted Deodhar decomposition

## Definition (G.-Gao-Gao '24+)

Fix a tilted reduced word  $\mathbf{v} = s_{i_1} s_{i_2} \cdots s_{i_\ell}$  of  $v$ . A **tilted distinguished subword** for  $u$  is  $\mathbf{u} = u_1 \cdots u_\ell$  where each  $u_k \in \{1, s_{i_k}, s_{i_k}, s_{i_k}\}$  that follows certain rules and their product is  $u$ . We denote  $\mathbf{u} \prec_t \mathbf{v}$ .

## Example

For  $u = 512346$  and  $v = 246513$ , given a tilted reduced word  $\mathbf{v} = s_3 s_4 s_5 s_1 s_2 s_3 s_4 s_3 s_2 s_1 s_2$ , there are 4 tilted distinguished subwords:

$$\mathbf{u} = 11111s_4s_3s_2s_111$$

$$\mathbf{u} = 111s_111s_4s_3s_2s_1s_2$$

$$\mathbf{u} = s_31111s_3s_4s_3s_2s_111$$

$$\mathbf{u} = s_311s_11s_3s_4s_3s_2s_1s_2$$

## Theorem (G.-Gao-Gao '24+)

$$\mathcal{T}_{u,v}^\circ = \bigsqcup_{\mathbf{u} \prec_t \mathbf{v}} D_{\mathbf{u},\mathbf{v}}, \text{ where each } D_{\mathbf{u},\mathbf{v}} \cong (\mathbb{C}^*)^{\#1\text{'s in } \mathbf{u}} \times \mathbb{C}^{\#s_{i_k}\text{'s in } \mathbf{u}}$$

# Tilted Schubert Variety

For  $w \in S_n$  and a sequence  $\mathbf{a} = (a_1, \dots, a_{n-1}) \in [n]^{n-1}$ , we define the **tilted Schubert cell**  $X_{w,\mathbf{a}}^\circ$  as follows.

# Tilted Schubert Variety

For  $w \in S_n$  and a sequence  $\mathbf{a} = (a_1, \dots, a_{n-1}) \in [n]^{n-1}$ , we define the **tilted Schubert cell**  $X_{w, \mathbf{a}}^\circ$  as follows.

## Example

Consider  $w = 3142(\bullet)$ ,

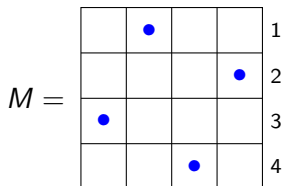

# Tilted Schubert Variety

For  $w \in S_n$  and a sequence  $\mathbf{a} = (a_1, \dots, a_{n-1}) \in [n]^{n-1}$ , we define the **tilted Schubert cell**  $X_{w,\mathbf{a}}^\circ$  as follows.

## Example

Consider  $w = 3142(\bullet)$ , and  $\mathbf{a} = (4, 4, 2)(-)$ .

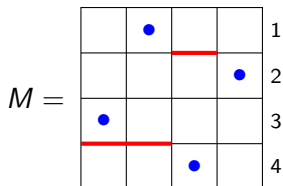

# Tilted Schubert Variety

For  $w \in S_n$  and a sequence  $\mathbf{a} = (a_1, \dots, a_{n-1}) \in [n]^{n-1}$ , we define the **tilted Schubert cell**  $X_{w,\mathbf{a}}^\circ$  as follows.

## Example

Consider  $w = 3142(\bullet)$ , and  $\mathbf{a} = (4, 4, 2)(-)$ .

Shoot death rays rightwards and upwards (cyclically till you hit red line)

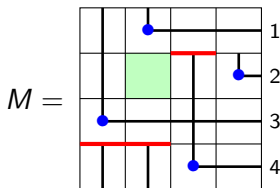

# Tilted Schubert Variety

For  $w \in S_n$  and a sequence  $\mathbf{a} = (a_1, \dots, a_{n-1}) \in [n]^{n-1}$ , we define the **tilted Schubert cell**  $X_{w,\mathbf{a}}^\circ$  as follows.

## Example

Consider  $w = 3142(\bullet)$ , and  $\mathbf{a} = (4, 4, 2)(-)$ .

Shoot death rays rightwards and upwards (cyclically till you hit red line)

Replace dead cells with 0 and empty cells with \*

$$M = \begin{array}{cccc|c} 0 & 1 & 0 & 0 & 1 \\ 0 & * & 0 & 1 & 2 \\ 1 & 0 & 0 & 0 & 3 \\ 0 & 0 & 1 & 0 & 4 \end{array}$$

# Tilted Schubert Variety

For  $w \in S_n$  and a sequence  $\mathbf{a} = (a_1, \dots, a_{n-1}) \in [n]^{n-1}$ , we define the **tilted Schubert cell**  $X_{w,\mathbf{a}}^\circ$  as follows.

## Example

Consider  $w = 3142(\bullet)$ , and  $\mathbf{a} = (4, 4, 2)(-)$ .

Shoot death rays rightwards and upwards (cyclically till you hit red line)

Replace dead cells with 0 and empty cells with \*

$$M = \begin{array}{cccc|c} 0 & 1 & 0 & 0 & 1 \\ 0 & * & 0 & 1 & 2 \\ 1 & 0 & 0 & 0 & 3 \\ 0 & 0 & 1 & 0 & 4 \end{array}$$

Define  $(X_{w,\mathbf{a}}^\circ)^\circ$  by shooting death rays downwards instead of upwards.

Define  $X_{w,\mathbf{a}}$  and  $X^{w,\mathbf{a}}$  by taking their closures, respectively.

# Tilted Schubert Variety

Theorem (G.-Gao-Gao '23)

*There exists a sequence  $\mathbf{a}$  such that  $\mathcal{T}_{u,v}^\circ = (X^{u,\mathbf{a}})^\circ \cap X_{v,\mathbf{a}}^\circ$ .*

# Tilted Schubert Variety

## Theorem (G.-Gao-Gao '23)

*There exists a sequence  $\mathbf{a}$  such that  $\mathcal{T}_{u,v}^\circ = (X^{u,\mathbf{a}})^\circ \cap X_{v,\mathbf{a}}^\circ$ .*

One direction in proof of dimension:

$$\text{codim } \mathcal{T}_{u,v}^\circ \leq \underbrace{\text{codim } (X^{u,\mathbf{a}})^\circ + \text{codim } X_{v,\mathbf{a}}^\circ}_{\# \text{ of } * \text{'s in the diagram}}$$

# Tilted Schubert Variety

## Theorem (G.-Gao-Gao '23)

There exists a sequence  $\mathbf{a}$  such that  $\mathcal{T}_{u,v}^\circ = (X^{u,\mathbf{a}})^\circ \cap X_{v,\mathbf{a}}^\circ$ .

One direction in proof of dimension:

$$\text{codim } \mathcal{T}_{u,v}^\circ \leq \underbrace{\text{codim } (X^{u,\mathbf{a}})^\circ + \text{codim } X_{v,\mathbf{a}}^\circ}_{\# \text{ of } * \text{'s in the diagram}}$$

However,  $X_{w,\mathbf{a}}^\circ$  are **worse** than Schubert varieties  $X_w^\circ$  since in general,

- they do not form a stratification;
- intersection of their closures  $X^{u,\mathbf{a}} \cap X_{v,\mathbf{a}} \neq \mathcal{T}_{u,v}$ ;
- they are not geometrically natural (can't generalize to other Lie type);
- their closures  $X_{w,\mathbf{a}}$  are not special cases of tilted Richardson varieties.